

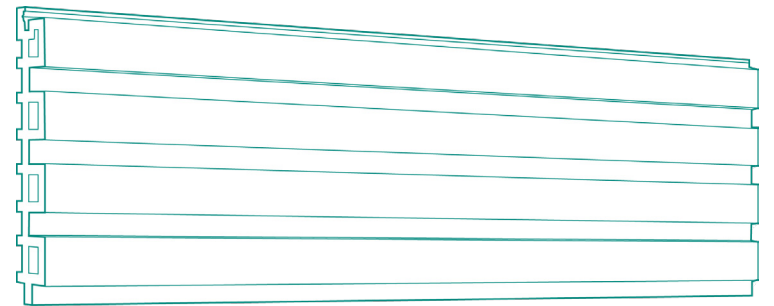

COMPOSITE CLADDING

Installation Guide
Elite range



 [assuredcomposite.com](https://www.assuredcomposite.com)

 info@assuredcomposite.com

 0800 802 1357



CONTENTS

Tips & Advice 4

.....

| | |
|--------------------------------------|---|
| Handling & storage | 6 |
| Recommended tools & safety equipment | 7 |

Installing Subframe 8

.....

| | |
|----------------------------|----|
| Subframe options | |
| Composite battens | 10 |
| Horizontal cladding layout | 11 |
| Vertical cladding layout | 12 |

Installing Cladding & Accessories 13

.....

| | |
|----------------------------|----|
| First cladding board | 14 |
| Horizontal cladding boards | 15 |
| Vertical cladding boards | 16 |
| Corner trim | 17 |
| Fascia | 18 |



TIPS & ADVICE



Plan your project

- Use a minimum of 2 people to make the project easier
- Plan all areas and think about what is trying to be achieved
- Measure twice to ensure the correct measurements are taken before cutting any material
- Ensure all working areas are clear and free from any obstacles to avoid damage or injury
- Clear all vegetation where necessary to avoid unnecessary growth
- Pre-drill holes where necessary to avoid splitting materials

Prepare for installation

- Double batten where cladding boards meet for support
- Allow a minimum 25mm space behind cladding boards for ventilation
- Allow expansion gaps where advised to avoid unnecessary repairs
- Only leave a maximum 20mm cladding board overhang

Recommended tools

- Only use Assured fasteners and fixings with Assured products
- Refer to manufacturers user manual before using tools if unsure

Safety first

- Always wear safety equipment
- Always have safety in mind

Not sure about anything regarding installation?

Please contact us

[assuredcomposite.com](https://www.assuredcomposite.com)

info@assuredcomposite.com

0800 802 1357

HANDLING & STORAGE

Looking after composite materials

When handling and storing our composite products follow the advice of our experts, this helps prevent damage and injury before installation

- When moving composite products please ensure the correct safety equipment is worn
- Check that the area where the products are being placed are clear and free from any obstacles
- Ensure the ground is a flat hard surface and place battens every 450mm approx intervals to support products above the ground
- We advise that 2 people move products due to the weight and length
- Do not drag or slide products especially when laying on top of one another
- Allow 24 hours for products to acclimatise to the environment before installation
- Any composite products stored for a long period of time will need to be covered

RECOMMENDED TOOLS & SAFETY EQUIPMENT

Safety matters

When installing our products you must install them as safely as possible. Ensure you have the right tools available which have been recommended by our team of experts



Tape Measure



Ladder



Impact Driver



Circular Saw



String Line



Safety Clothing

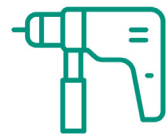

Hammer Drill



Set Square



Jigsaw



Spirit Level



Clamp

If you are unsure on how to use any tool refer to the manufacturers user manual before continuing





INSTALLING SUBFRAME

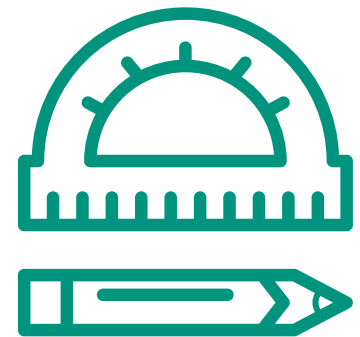

INSTALLING SUBFRAME

Subframe options

We advise you first to consider a layout pattern for your cladding project. You have the option of either a horizontal or a vertical cladding layout. The joist layout will run the opposite way to the cladding

Horizontal Cladding

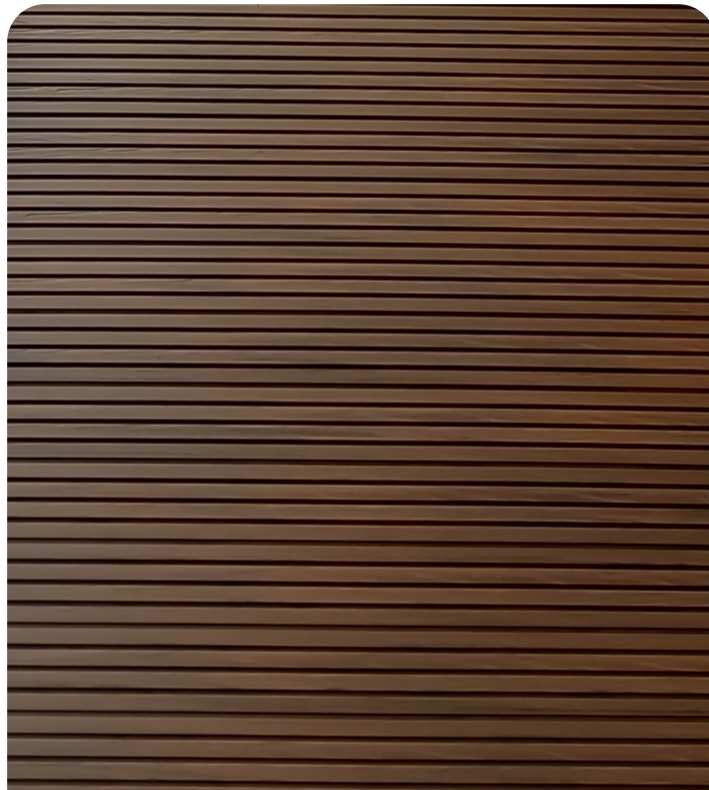

Vertical Cladding

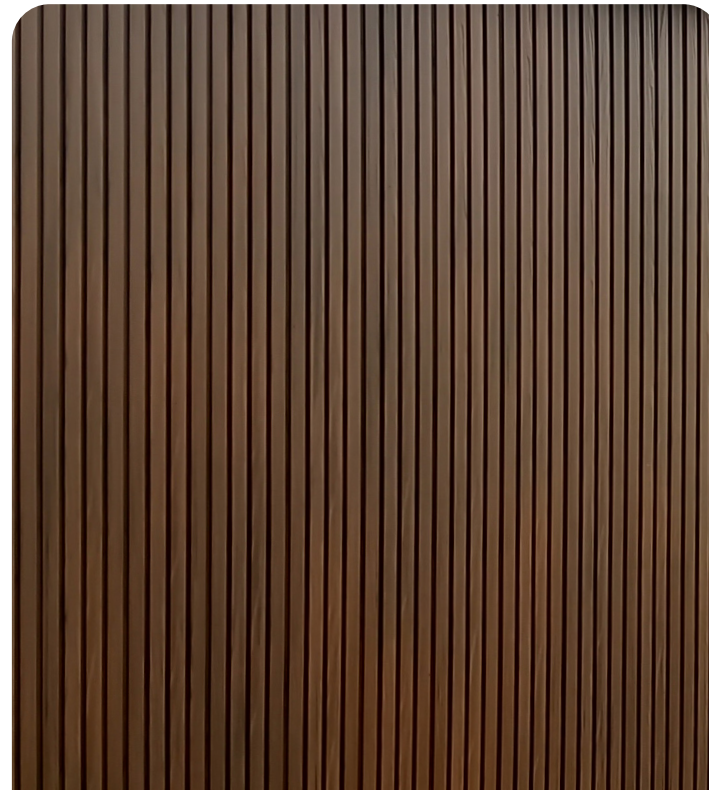

Subframe options

Various batten options can be used when installing composite cladding including steel, aluminium, plastic, timber or composite. If you are installing battens for horizontal cladding then please refer to page 11. If you are installing battens for vertical cladding then please refer to page 12

- Ensure the wall is solid and flat and the area is clear and free from any obstacles including cables and pipes. If a waterproof membrane is required install this before the battens
- Keep 10mm expansion gaps from the ground, roof, side walls and at batten butt joins

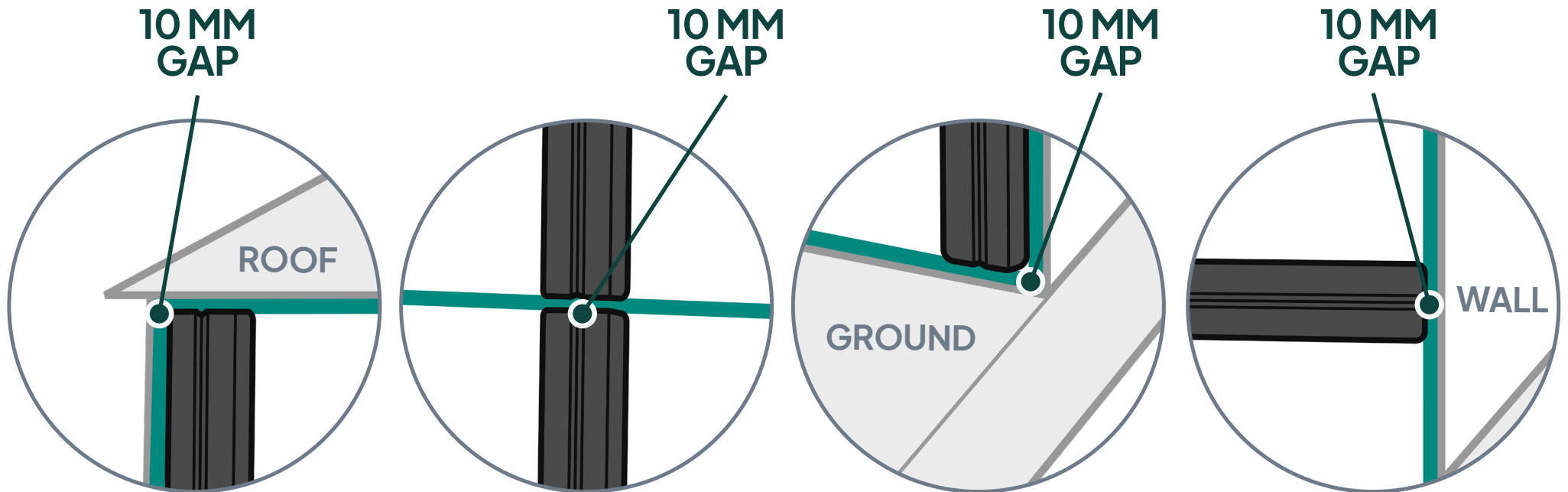

HORIZONTAL CLADDING LAYOUT

Carefully plan the area checking all measurements. Measure and cut battens where required

- 1 Fix battens into position leaving 300mm max intervals between each batten centre to centre
- 2 Fix battens into place with expansion screws by drilling holes through the middle groove of each batten and into the wall. Start at 80mm approx then at 500mm approx intervals
- 3 Double batten where cladding boards meet at butt joints allowing a 3mm gap between battens

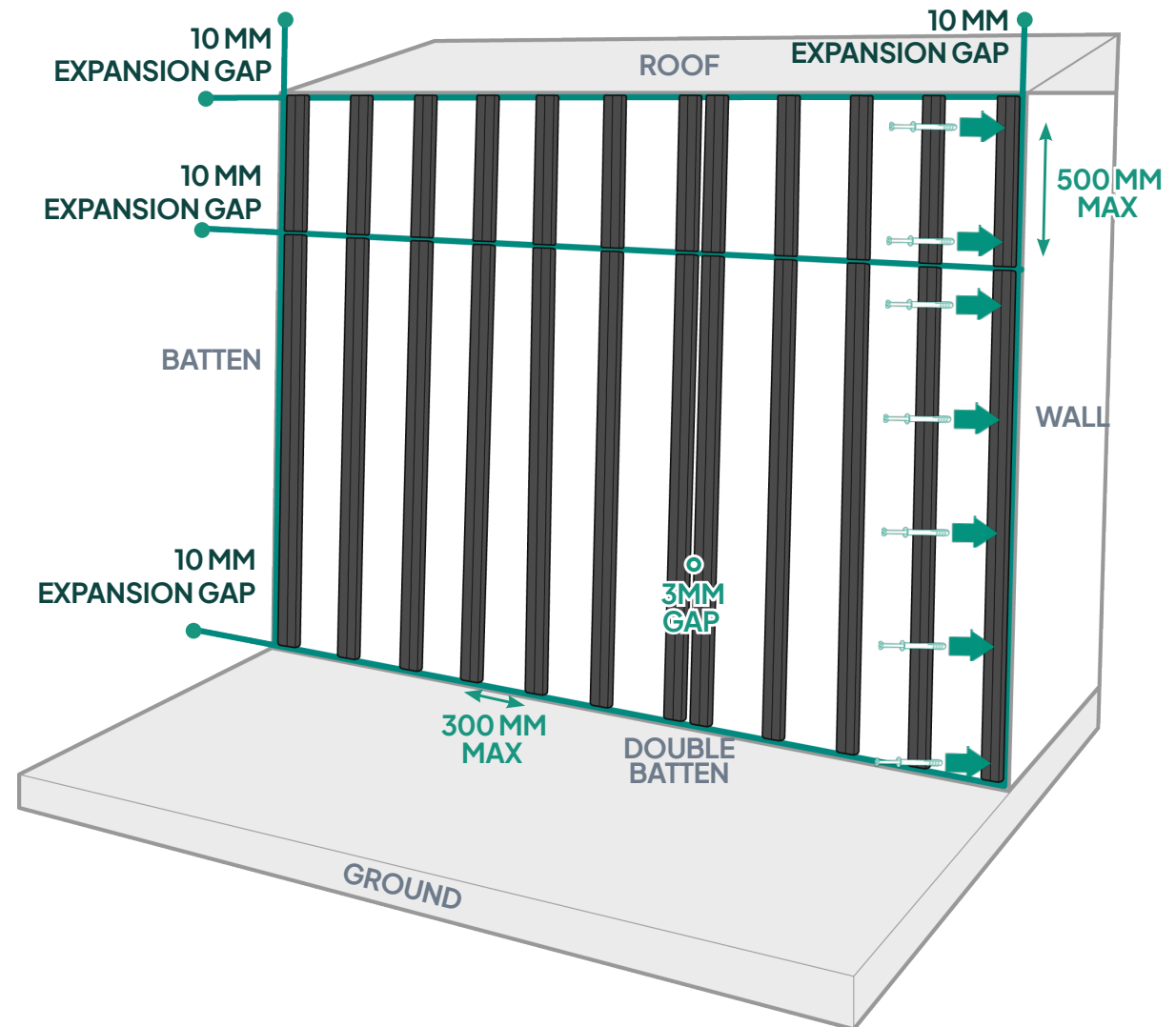
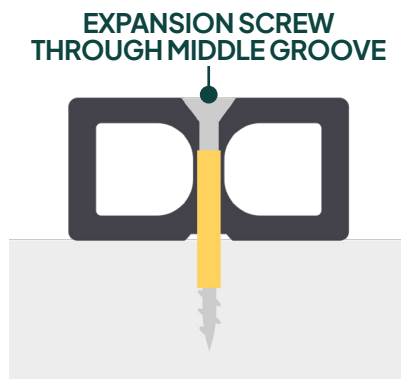

VERTICAL CLADDING LAYOUT

Carefully plan the area checking all measurements. Measure and cut battens where required

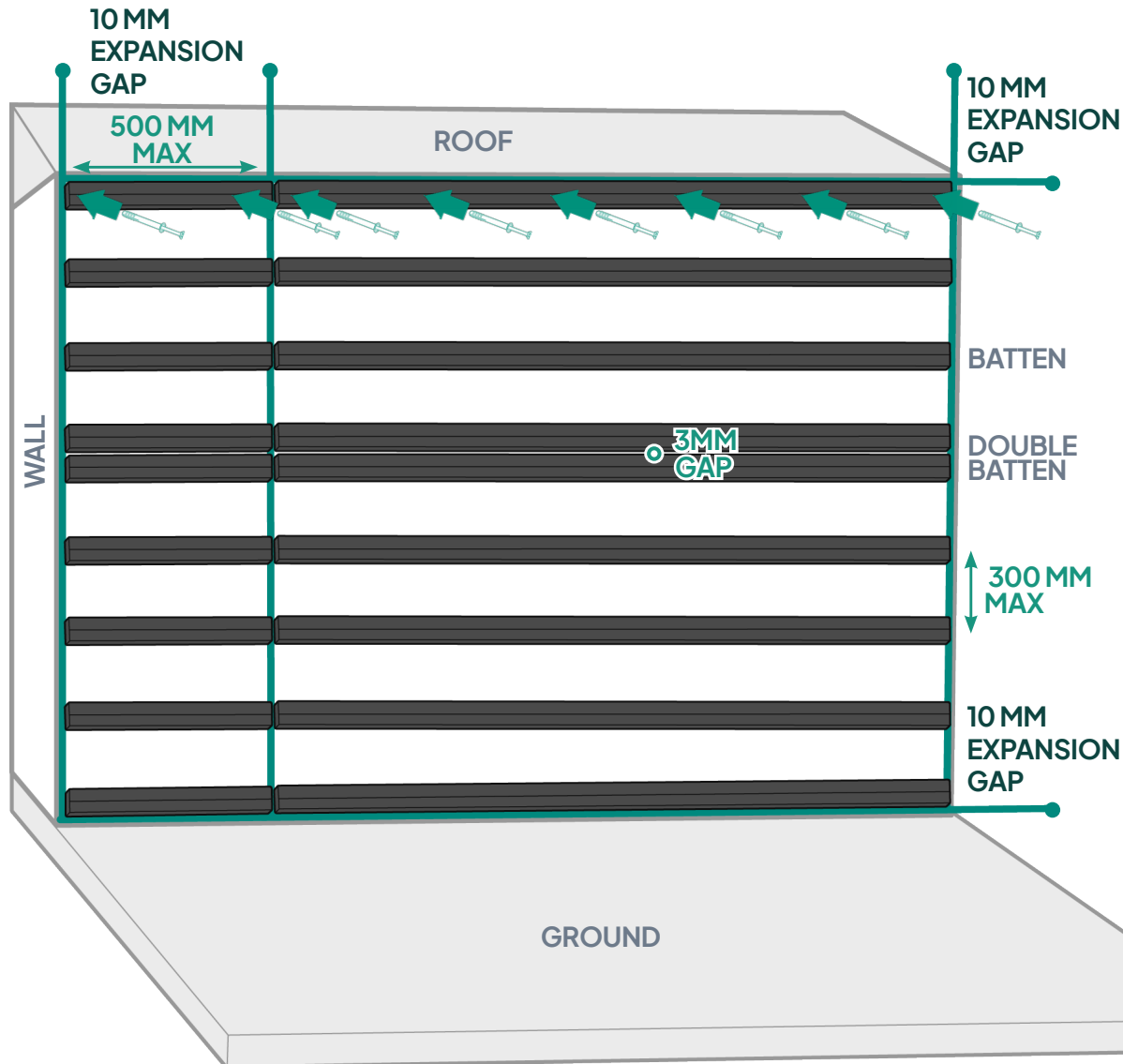

- 1 Fix battens into position leaving 300mm max intervals between each batten centre to centre
- 2 Fix battens into place with expansion screws by drilling holes through the middle groove of each batten and into the wall. Start at 80mm approx then at 500mm approx intervals
- 3 Double batten where cladding boards meet at butt joins allowing a 3mm gap between battens

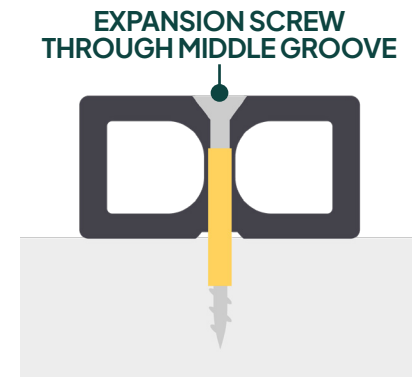



CLADDING & ACCESSORIES



INSTALLING FIRST CLADDING BOARD

- 1 Ensure the first cladding board is the correct way with the tongue at the bottom (horizontal) or side (vertical) and is level before fixing
- 2 Fix cladding board to the framework at every batten. Screw between the first 2 slats ensuring that the screws are fully screwed into place
- 3 Pre-drill holes and screw through the groove of the cladding board and into each batten to secure. Ensure that the screws are fully screwed into place to prevent catching on the next cladding board
- 4 If installing horizontal cladding please refer to page 15. If installing vertical cladding please refer to page 16

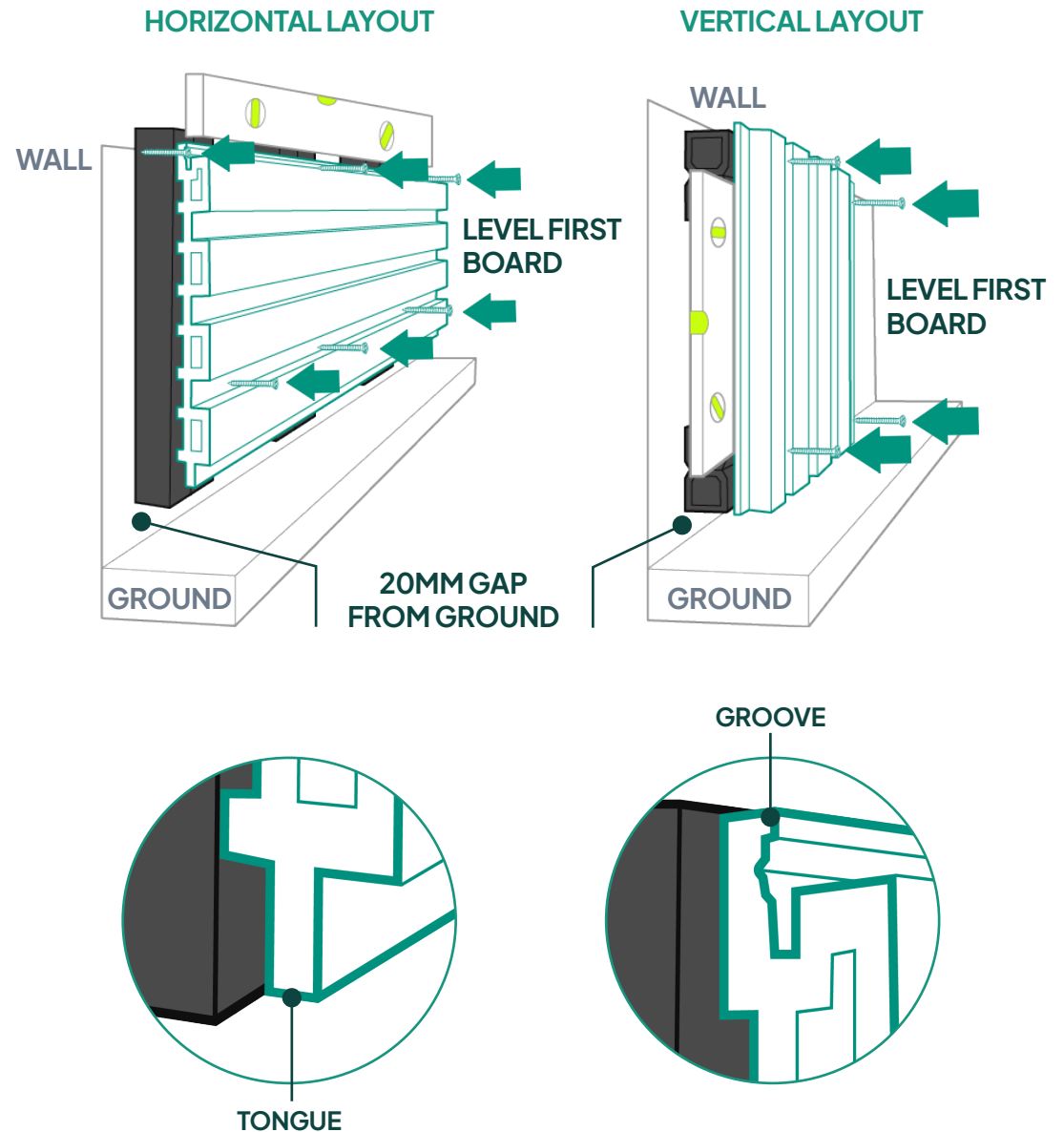

INSTALLING HORIZONTAL CLADDING BOARDS

- 1 Continue with the same process until the last cladding board cutting cladding boards where required. Leave 8mm expansion gaps between cladding board butt joins
- 2 If the last cladding board does not fit as a whole then cut the cladding board to size. In some cases you may need to fix between the last 2 slats to secure

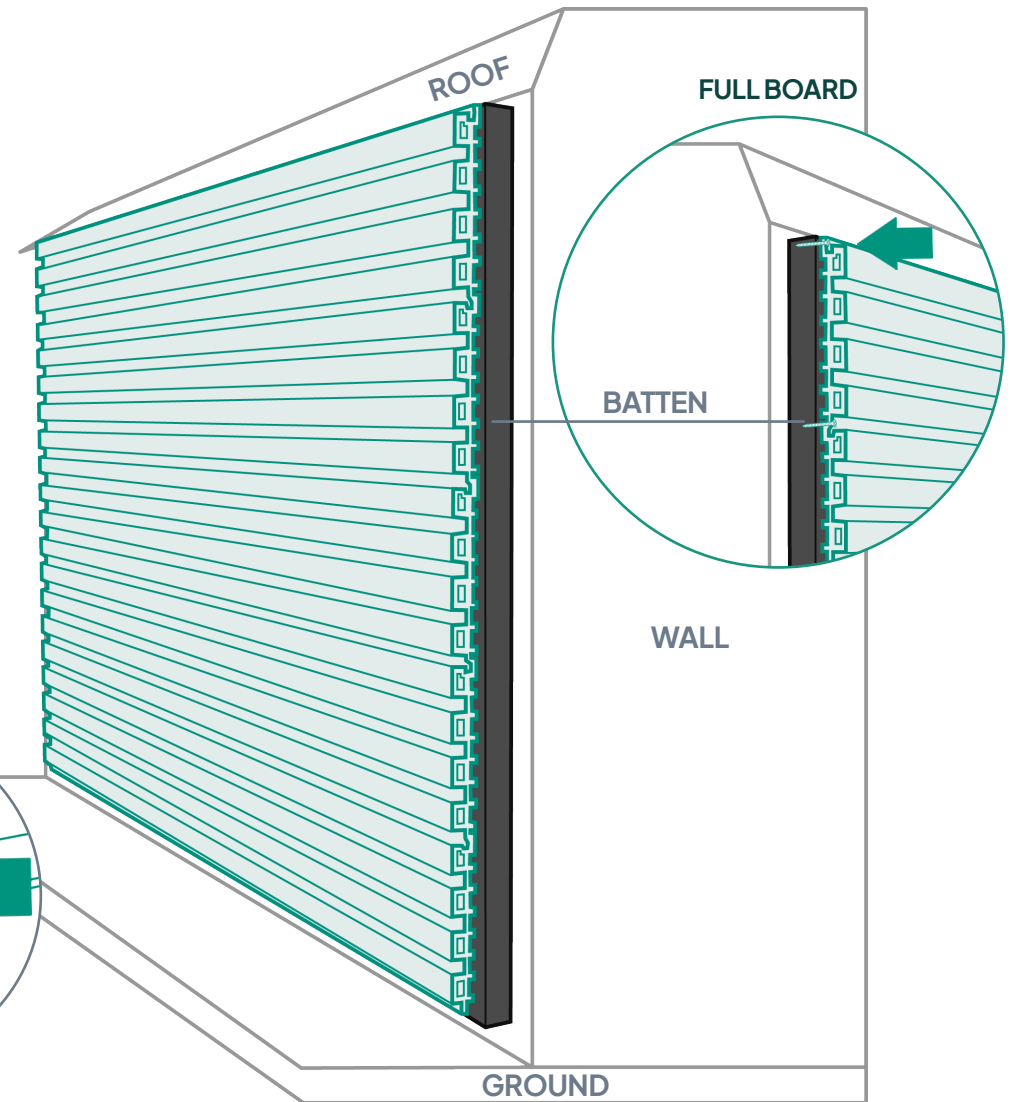
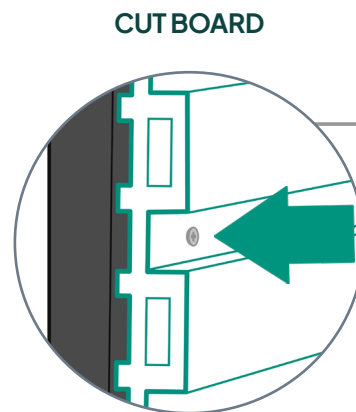
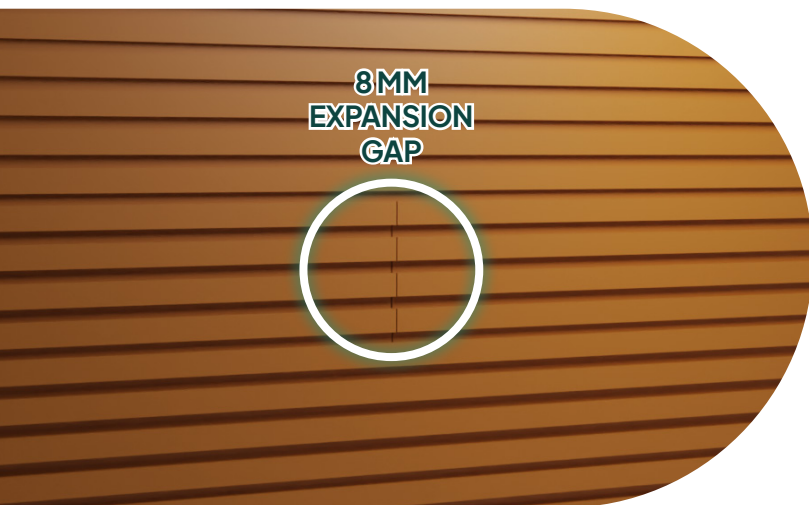

INSTALLING VERTICAL CLADDING BOARDS

- 1 Continue with the same process until the last cladding board cutting cladding boards where required. Leave 8mm expansion gaps between cladding board butt joins
- 2 If the last cladding board does not fit as a whole then cut the cladding board to size. In some cases you may need to fix between the last 2 slats to secure

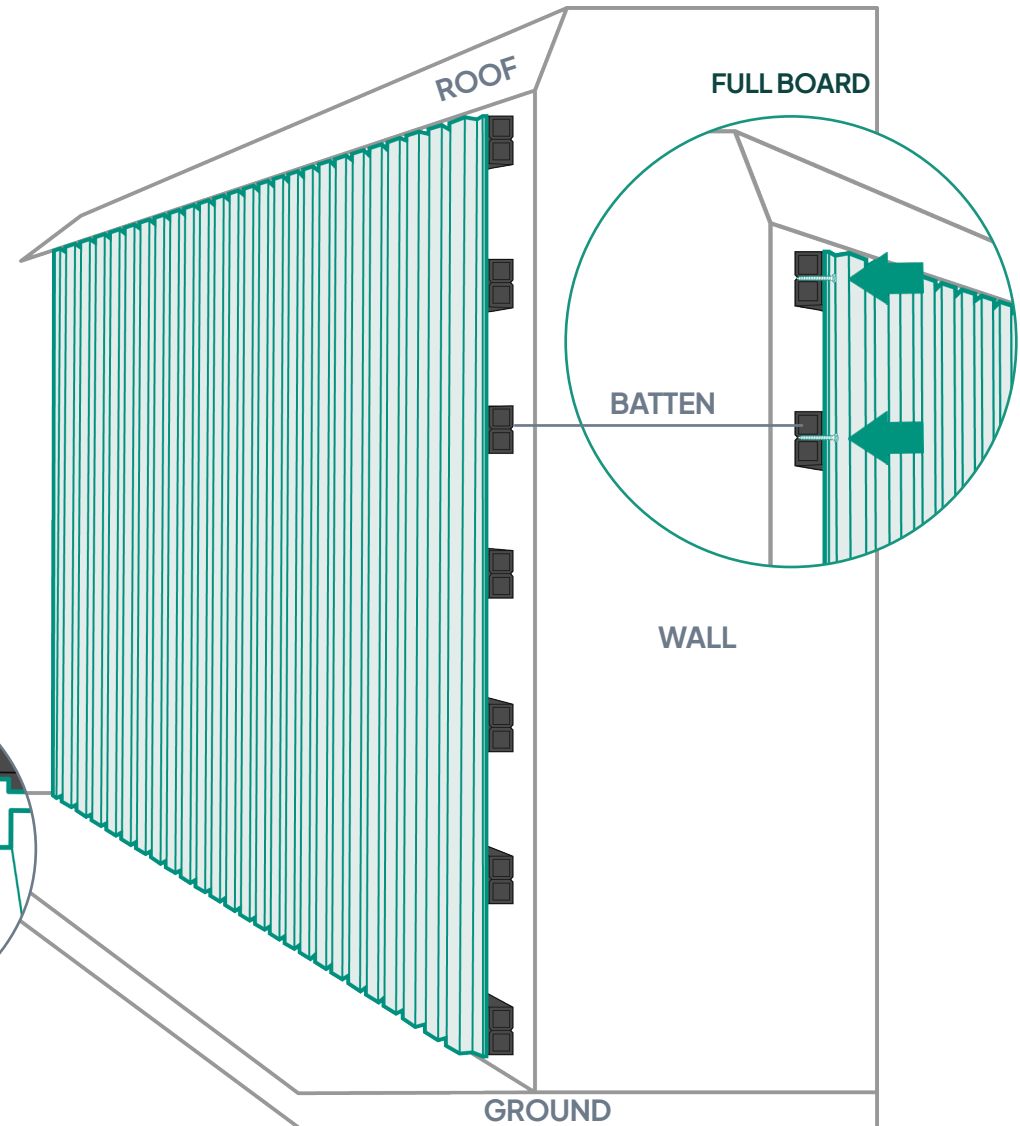

8MM
EXPANSION
GAP



CUT BOARD

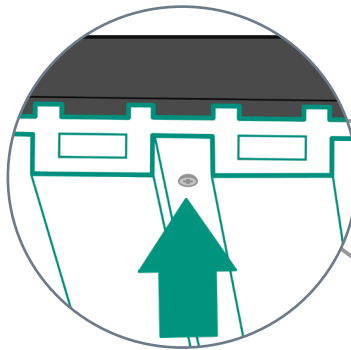

Carefully plan the area checking all measurements. Measure and cut corner trim where required

- 1 Fix the corner trim by covering the cladding board edge
- 2 Pre-drill holes and fix into place by screwing directly through the corner trim and into the cladding board. Start at 80mm approx and then at every 300mm approx intervals. Leave a 2mm expansion gap when joining corner trim

Corner trim can also be fixed into place using a high bond strength grab adhesive

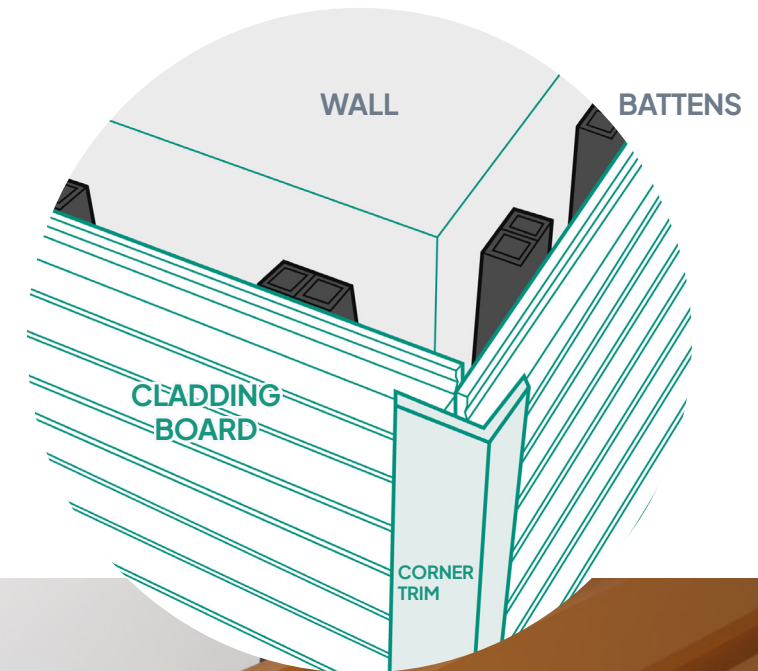

INSTALLING FASCIA

Carefully plan the area checking all measurements. Measure and cut battens and fascia where required

- 1 Fix battens into position leaving a 2mm expansion gap at either end
- 2 Fix the fascia by pre-drilling holes top and bottom and screwing through the face of the fascia. Start at 80mm approx then at every 300mm approx intervals. Ensure that the fascia finishes flush with the cladding board. Leave a 2mm expansion gap when joining fascia

Fascia can also be fixed into place using a high bond strength grab adhesive

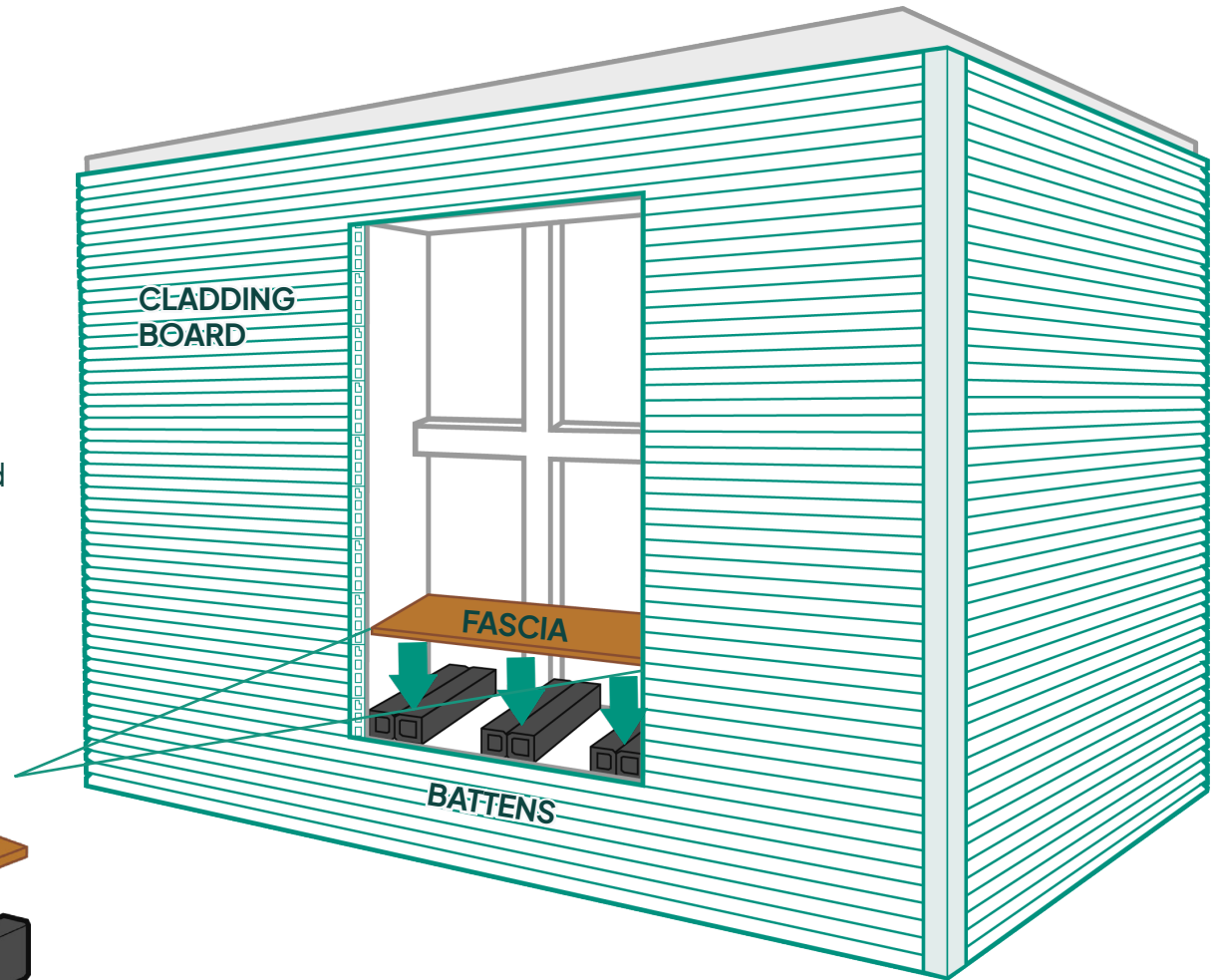
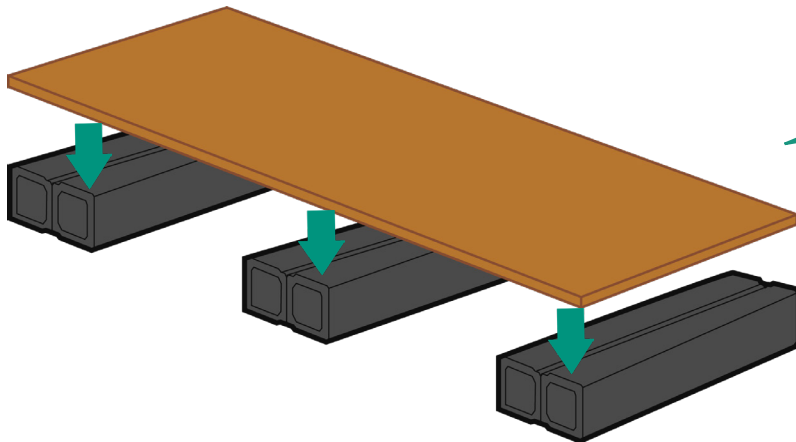



— ASSURED —
AC COMPOSITE

assuredcomposite.com

info@assuredcomposite.com

[0800 802 1357](tel:08008021357)